

ES250

Spider Lift

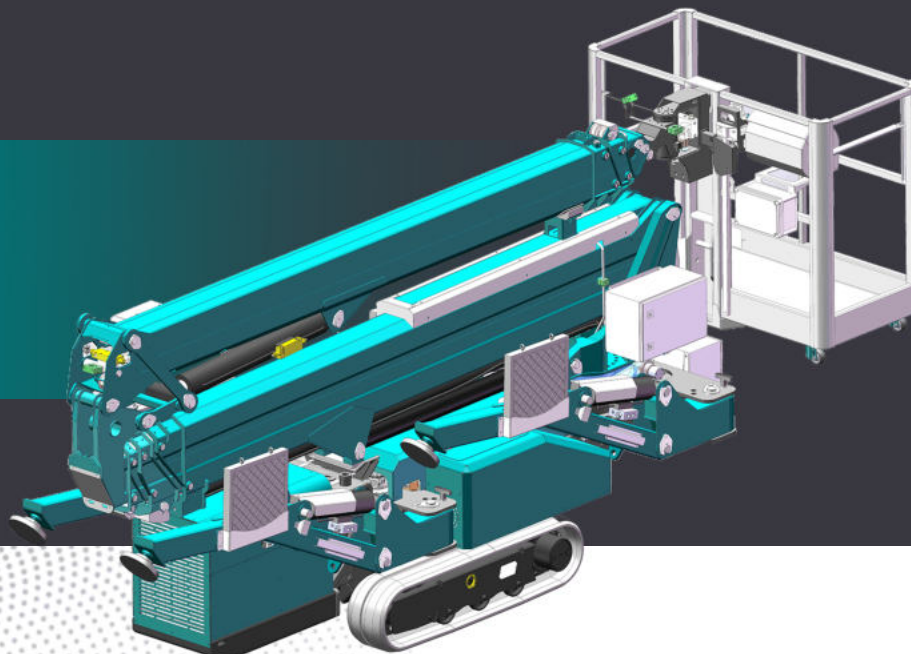

STANDARD EQUIPMENT

- Articulated with double telescopic booms
- 360° continuous turret rotation
- $\pm 80^\circ$ platform rotation
- CAN-bus controlled
- One-button outrigger leveling
- Variable outrigger system
- Radio remote control
- Go home function
- Track width adjusting system
- White non-marking rubber tracks
- Full proportional control system
- Auto leveling platform
- Emergency hand pump
- Hour meter
- Hydraulic safety devices
- Platform overload sensor
- Removable aluminium platform
- Real-time data display in the control panel
- Double speed drive
- AC220V electric motor
- Standard painting: RAL5021
- AC220V electric socket in the platform
- Storage box for the radio
- Diesel engine

ACCESSORIES

- 4 sliding pads
- Proportional valve emergency lever
- AC220V power cable for electric motor
- 10m control cable for radio
- 2 NiMH batteries(2400mAh) for radio

OPTIONS

- Special painting
- 51.2V-275AH Lithium battery
- Black standard rubber tracks
- Lifting device (260kg capacity)
- Anti-collision kit for the platform

**REACH HIGHER
WITH INNOVATION**

Model	ES250
TECHINCAL DATA	
Working height, max.	24.5 m
Platform height, max.	22.5 m
Horizontal outreach, max.	11 m
Up and over clearance, max.	13.8 m
Negative working capacity, max	- 4.2 m
Track width-adjustable	900 mm / 1150 mm
Total weight	3380 kg
A Platform (length)	1.5 m
B Platform (width)	0.7 m
C Platform (height)	1.1 m
D Stowed length	4975 mm
E Stowed length (without platform)	4530 mm
F Stowed width	1500 mm
G Stowed width (without platform)	900 mm
H Stowed height	1980 mm
I Length-outrigger footprint	3690 mm / 4910 mm
J Width-outrigger footprint	2560 mm / 3745 mm
K Track (length*width)	1425 mm x 230 mm
Live load in travelling position	4.53 kN/m ²
Live load in working position	2.44 kN/m ²
PERFORMANCE	
Platform capacity, max.	230 kg
Gradeability, max.	30%
Travel speed, max.	1.3 km/h
Platform rotatable	±80°
Turntable rotation, max.	360°(continuous)
Standard painting	RAL5021
Control	Radio remote control
POWER SOURCES	
Combustion engine (Diesel)	Kubota D902 15.9kw
Electric motor	AC220V / 3kw
Lithium battery (Optional)	51.2V-275AH

